

# Decolife Zip 100

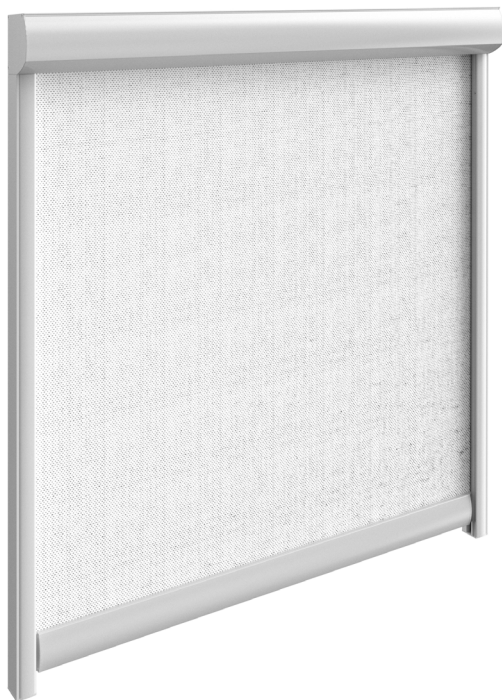

**gaviota**  
toldos y persianas inteligentes

- E Instrucciones de montaje**  
Leer detenidamente estas instrucciones de montaje antes de cualquier uso y conservarlas después de la instalación.
- GB Assembly directions**  
Read carefully these instructions before any use and keep them after the installation.
- F Instructions de montage**  
Lire ces instructions de montage avant l'utilisation et conservez-les après l'installation.
- I Istruzioni di montaggio**  
Istruzioni di montaggio. Leggere accuratamente queste istruzioni di montaggio prima di qualsiasi uso e conservarle dopo l'installazione.

IP	CÓDIGO / CODE	DESCRIPCION	DESCRIPTION	DESCRIPTION	DESCRIZIONE	UDS. UNITS
1	80170120	JGO. TESTERO SCREEN UNIVERSAL ZP BLANCO	SET OF CAPS UNIVERSAL ZP SCREEN, WHITE	JEU CONSOLES UNIVERSAL ZP BLANC	FANCO TESTATA SCREEN UNIVERSAL ZP BIANCO	1
2a	80170192	SOPORTE MOTOR COMPATIBLE GANOTA SIMBAC-SMU SCREEN UNIVERSAL ZP	MOTOR SUPPORT COMPATIBLE GANOTA SIMBAC-SMU UNIVERSAL ZP SCREEN	SUPPORT MOTOR COMP. GANOTA SIMBAC-SMU UNIVERSAL ZP	SUPPORTO MOTORE COMPATIBILE GANOTA SIMBAC-SMU SCREEN UNIVERSAL ZP	1
2b	80170193	SOPORTE MOTOR COMPATIBLE SOMFY SCREEN UNIVERSAL ZP	MOTOR SUPPORT COMPATIBLE SOMFY UNIVERSAL ZP SCREEN	SUPPORT MOTOR COMP. SOMFY UNIVERSAL ZP	SUPPORTO MOTORE COMPATIBILE SOMFY SCREEN UNIVERSAL ZP	1
3	80170189	ANELLO DI FUGAGGIO SCREEN UNIVERSAL ZP 0/2	0/2 FRICTION RING, UNIVERSAL ZP SCREEN	ANNEAU FRICTION UNIVERSAL ZP 0/2	ANELLO DI FESSAGGIO SCREEN UNIVERSAL ZP 0/2	1
4	80170190	ANELLO DI FUGAGGIO SCREEN UNIVERSAL ZP 0/3	0/3 FRICTION RING, UNIVERSAL ZP SCREEN	ANNEAU FRICTION UNIVERSAL ZP 0/3	ANELLO DI FESSAGGIO SCREEN UNIVERSAL ZP 0/3	1
5a	80200012	CASULLO 78 RANFARUDO PLASTICO PUNTO R1-4	ROUND CAP OF 78 WITH ROUND HOLE OF 4, IN PLASTIC	EMBOÛT FEMELLE 78 CÔTE OPPOSÉE R1-4	CALOTTA OSOVA Ø78 FORO Ø4	1
5b	80200020	CASULLO 78 RANFARUDO PLASTICO PUNTO R1-4	ROUND CAP OF 78 WITH SQUARE HOLE OF 13, IN PLASTIC	EMBOÛT FEMELLE 78 CÔTE OPPOSÉE R-14	CALOTTA OSOVA Ø78 FORO Ø13 PLASTICA	1
6a	80200025	CASULLO 78 RANFARUDO PLASTICO TRANSMISSOR C-13	DRIVING ROUND CAP OF 78 WITH SQUARE HOLE OF 13, IN PLASTIC	EMBOÛT FEMELLE 78 CÔTE MANCANGIARE C-13	CALOTTA OSOVA Ø78 FORO Ø13 PLASTICA	1
6b	80200024	CASULLO 78 RANFARUDO PLASTICO TRANSMISSOR C-13	DRIVING ROUND CAP OF 70 WITH SQUARE HOLE OF 13, IN PLASTIC	EMBOÛT FEMELLE 70 CÔTE MANCANGIARE C-13	CALOTTA OSOVA Ø70 FORO Ø13 PLASTICA	1
7a	80170011	CASULLO ADAPTOR POOLA TUBO 78 SCREEN RIS	ADAPTOR CAP FOR PULLEY, TUBE, RIS SCREEN	EMBOÛT ADAPTEUR POULE TUBE 78, STORE VERTICAL, RIS	CALOTTA ADATT PER PULEGGIA TUBO 78 SCREEN RIS	1
7b	80170147	CASULLO ADAPTOR POOLA TUBO 78 SCREEN RIS	ADAPTOR CAP FOR PULLEY, TUBE, RIS SCREEN	EMBOÛT ADAPTEUR POULE TUBE 70, STORE VERTICAL, RIS	CALOTTA ADATT PER PULEGGIA TUBO 70 SCREEN RIS	1
8	80170012	ANELLO DI FUGAGGIO SCREEN RIS	FRICTION RING, RIS SCREEN	ANNEAU FRICTION, STORE VERTICAL, RIS	ANELLO DI FESSAGGIO SCREEN RIS	1
9	80170083	SOPORTE INTERIOR SCREEN UNIVERSAL SE	INSIDE BRACKET WITHOUT PIVOT, UNIVERSAL SCREEN	SUPPORT INTERIEUR STORE VERTICAL, UNIVERSAL, ST	SUPPORTO INTERNO SCREEN UNIVERSAL	2
10	80170194	ANELLO COMPENSACION 013 1415 SCREEN UNIVERSAL ZP	COMPENSATION RING 013 1415, UNIVERSAL ZP SCREEN	ANNEAU COMP. 013 1415 UNIVERSAL ZP	ANELLO COMPENSACION 013 1415 SCREEN UNIVERSAL ZP	1
11	80170197	INSERTO METALICO C-1307 SCREEN UNIVERSAL ZP	C-1307 METALLIC INSERTION, UNIVERSAL ZP SCREEN	INSERT METALLIQUE C-1307 UNIVERSAL ZP	INSERTO METALICO C-1307 SCREEN UNIVERSAL ZP	1
12	80170195	CASULLO COMP. 01222A18 SCREEN UNIVERSAL ZP	012-22A18 COMPENSATION CAP UNIVERSAL ZP SCREEN	EMBOÛT COMP. 01222A18 UNIVERSAL ZP	CALOTTA COMPENSACIONE 01222A18 SCREEN UNIVERSAL ZP	1
13	80170196	PIETRA 4 MM ØE-12=15MM ZINGOLA	4 MM ØE-12=15MM CASSETTE, ZINC COATED	PLATINE 4 MM ØE-12 = 15MM ZINGLÉ	PIASTRA 4 MM ØE-12 = 15MM ZINGOLA	1
14	80170045	TOPE BARRA CARBA BIANCO SCREEN RIS	STOPPER FOR CHARGE PROFILE, WHITE, RIS SCREEN	BUTEE BARRE DE CHARGE BLANC, STORE VERTICAL, RIS	TAPPO BARRA TERMINALE BIANCO SCREEN RIS	4
15	80170191	JGO. TAPA GUA SCREEN UNIVERSAL ZP	SET OF CAPS FOR GUIDE, UNIVERSAL ZP SCREEN	JEU ENBOÛT OULUSSE UNIVERSAL ZP	CALOTTE GUIDA SCREEN UNIVERSAL ZP	1
16	80170019	EMBOUDO SCREEN RIS	RIS SCREEN ENTRY GUIDE	EMBOÛT STORE VERTICAL, RIS	CALOTTA CASS. SCREEN RIS	2
17	80170020	MIS. PEFEL CERRE LUNA PVC SCREEN RIS 7M	CLOSING PROFILE IN METERS, PVC FABRIC, RIS SCREEN 7M	MIS. PROFIL FERMÉ TOLE PVC, STORE VERTICAL, RIS 7M	PROFILO DI CHIUSURA TESSUTO PVC SCREEN RIS 7M	2
18	80170102	MIS. PEFEL CALUM BIANCO SCREEN UNIVERSAL 100 7M	SET OF BOX PROFILES IN METERS, 100 UNIVERSAL SCREEN, WHITE, 7M	JEU PROFILS CALUM, TOLE PVC, STORE VERTICAL, 7M BLANC	PROFILO CASSONETTO SCREEN UNIVERSAL BIANCO 7M	1
19	80170030	MIS. PEFEL GUÌA ANTERIOR SCREEN RIS BLANCO 7M	FRONTAL GUIDE PROFILE IN METERS, RIS SCREEN 7M, WHITE	MIS. PROFILS COFFRE, 100 STORE UNIVERSAL 7M BLANC	PROFILO GUIDA ANTERIORE BIANCO SCREEN RIS 7M	2
20	80170202	MIS. PEFEL GUÌA POSTERIOR SCREEN UNIVERSAL ZP BLANCO 7M	REAR GUIDE PROFILE IN METERS, UNIVERSAL ZP SCREEN, WHITE, 7M	MIS. PROFIL OULUSSE POSTERIEUR BLANC, UNIVERSAL ZP 7M	PROFILO GUIDA POSTERIORE SCREEN UNIVERSAL ZP BIANCO 7M	2
21	80170038	MIS. PEFEL BARRA CARBA SCREEN RIS BLANCO 7M	CHARGE PROFILE IN METERS, RIS SCREEN 7M, WHITE	MIS. PROFIL BARRE DE CHARGE BLANC, STORE RIS 7M	PROFILO BARRA TERMINALE SCREEN RIS 7M	1
22a	80170058	BARRA REFORZADO ACERO Ø22 - SCREEN RIS BLANCO 4M	Ø22 STEEL REINFORCEMENT BAR, RIS SCREEN 4M	BARRE RENFORCÉ ACÉR Ø22 - STORE VERTICAL, RIS 4M	BARRA RINFORZATO ACCIAIO Ø22 - 4M SCREEN RIS	36/mhm
22b	80170118	BARRA REFORZADO ACERO Ø12 - SCREEN UNIVERSAL 4M	Ø12 STEEL REINFORCEMENT BAR, UNIVERSAL SCREEN 4M	BARRE RENFORCÉ ACÉR Ø12 - STORE VERTICAL, UNIVERSAL 4M	BARRA RINFORZATO ACCIAIO Ø12 - 4M SCREEN UNIVERSAL	16/mhm
23	80170057	NEOPRENE AUTO-ADHESIVO 100x1MM SCREEN RIS	100x1 MM SELF-ADHESIVE NEOPRENE, RIS SCREEN	NEOPRENE AUTO-COLLANT 100x1MM, STORE VERTICAL, RIS	NEOPRENE AUTO-ADHESIVO 100x1MM SCREEN RIS	2 jus 140cm
24	80170084	FELPUDO SCREEN RIS L=5M	5M MAT, RIS SCREEN	JOINT BROUSSE COUPE 5 M, STORE VERTICAL, RIS	SPAZZOLINO TAGLIATO 5M SCREEN RIS	1
25	80170082	SUECION PEFEL SCREEN UNIVERSAL 100/PAREAD	100 PROFILE FRICTION SUPPORT FOR WALL, UNIVERSAL SCREEN	100 PROFIL FRICTION SUPPORT A MUR, STORE VERTICAL, UNIVERSAL	PROFILO 100 DI SUPPORTO A PARETE SCREEN UNIVERSAL	7,5/kgb/z
26	80170083	SUECION PEFEL SCREEN UNIVERSAL 100/PITECHO	100 PROFILE FRICTION SUPPORT FOR CEILING, UNIVERSAL SCREEN	100 PROFIL FRICTION SUPPORT PLAFOND, STORE VERTICAL, UNIVERSAL	PROFILO 100 DI SUPPORTO A TETTO SCREEN UNIVERSAL	7,5/kgb/z
27		TORNILLO ALLEN M4X25,0X Ø2,0X	M4X25 DIM Ø2,0 SST ALLEN SCREW	VIS ALLEN M4X25 DIM Ø2,0 INOX	VITE M4X25 DIM Ø2,0 INOX	10
28		TORNILLO M8X10 DIM-7,9Ø1 INOX	M8X10 DIM-7,9Ø1 SST SCREW	MIS M8X10 DIM-7,9Ø1 INOX	VITE M8X10 DIM-7,9Ø1 INOX	2
29		TORNILLO 03,5X16 DIM-7,9Ø2 INOX	Ø3,5X16 DIM-7,9Ø2 SST SCREW	MS Ø3,5X16 DIM-7,9Ø2 INOX	VITE Ø3,5X16 DIM-7,9Ø2 INOX	2
30		TORNILLO 02,5X16 DIM-7,9Ø1 SST SCREW	Ø2,5X16 DIM-7,9Ø1 SST SCREW	MS 02,5X16 DIM-7,9Ø1 INOX	VITE Ø2,5X16 DIM-7,9Ø1 INOX	2
31		TORNILLO 03,5X32 DIM-7,9Ø2 INOX	Ø3,5X32 DIM-7,9Ø2 SST SCREW	MS 03,5X32 DIM-7,9Ø2 INOX	VITE Ø3,5X32 DIM-7,9Ø2 INOX	6
32		TORNILLO CAMEL PHIL M MAZ5 DIM-Ø65 INOX	M4Ø DIM-Ø65 SST PHILIPS HAZELNUT SCREW	VIS A TÊTE FRANSÉE PHILIPS M4Ø DIM-Ø65 INOX	VITE CAMEL PHIL M MAZ5 DIM-Ø65 INOX	2
33		TORNILLO CUADRO M4 DIM-5Ø2 INOX	M4 DIM-5Ø2 SST SQUARE NUT	ECROU CARRE M4 DIM-5Ø2 INOX	DAIDO QUADRO M4 DIM-5Ø2 INOX	2
34		TORNILLO 03,5X6,5 DIM-7,9Ø1 SST SCREW	Ø3,5X6,5 DIM-7,9Ø1 SST SCREW	MS 03,5X6,5 DIM-7,9Ø1 INOX	VITE Ø3,5X6,5 DIM-7,9Ø1 INOX	2
35		TORNILLO CAMEL PHIL M MAZ5 DIM-Ø65 INOX	M4X25 DIM-Ø65 SST PHILIPS HAZELNUT SCREW	VIS A TÊTE FRANSÉE PHILIPS M4X25 DIM-Ø65 INOX	VITE CAMEL PHIL M MAZ5 DIM-Ø65 INOX	2
36		TORNILLO Ø4X6,14 DIM-ØØ4 INOX	M4-DIM-ØØ4 SST HEXAGONAL NUT	ECROU Ø4X6,14 DIM-ØØ4 INOX	DAIDO ESCONALE M4-DIM-ØØ4 INOX	2
37		TORNILLO CAMEL PHIL M8X10 DIM-Ø65 ZINCADO	M8X10 DIM-Ø65 ZMC COATED PHILIPS HAZELNUT SCREW	VIS A TÊTE FRANSÉE PHILIPS M8X10 DIM-Ø65 ZINGHE	VITE ZINCAPI PHIL M8X10 DIM-Ø65	2

**(E)** Esquema Screen Universal Zip con Motor

**(GB)** Universal Zip Screen with Motor

**(F)** Schéma Store Vertical Universal Zip Motorisé

**(I)** Schema Screen Universal Zip con Motore

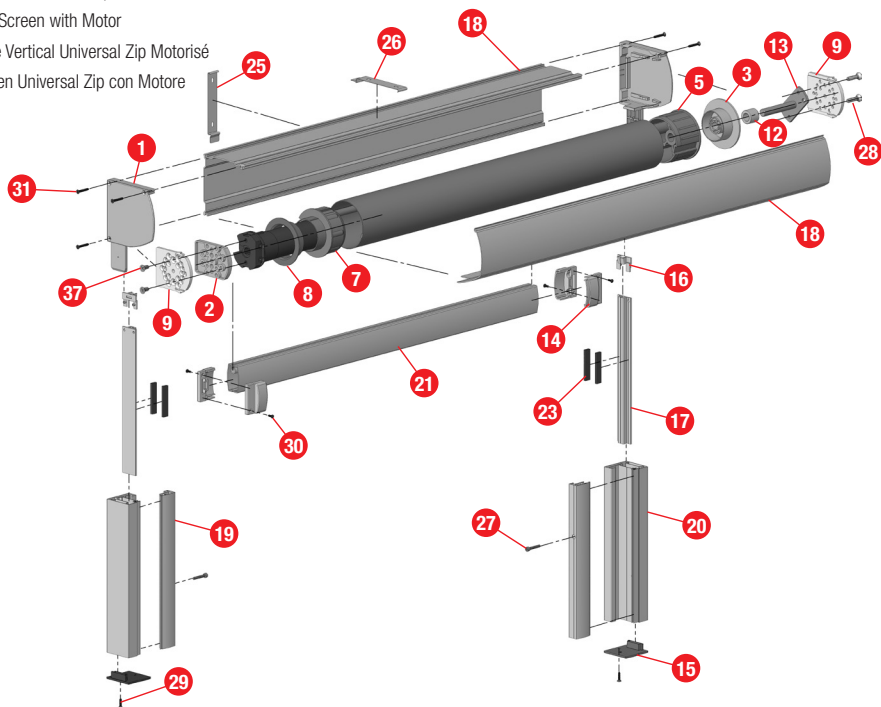

**(E)** Esquema Screen Universal Zip con Cardan

**(GB)** Universal Zip Screen with Gear

**(F)** Schéma Store Vertical Universal Zip avec Treuil à Vis

**(I)** Schema Screen Universal Zip con Argano

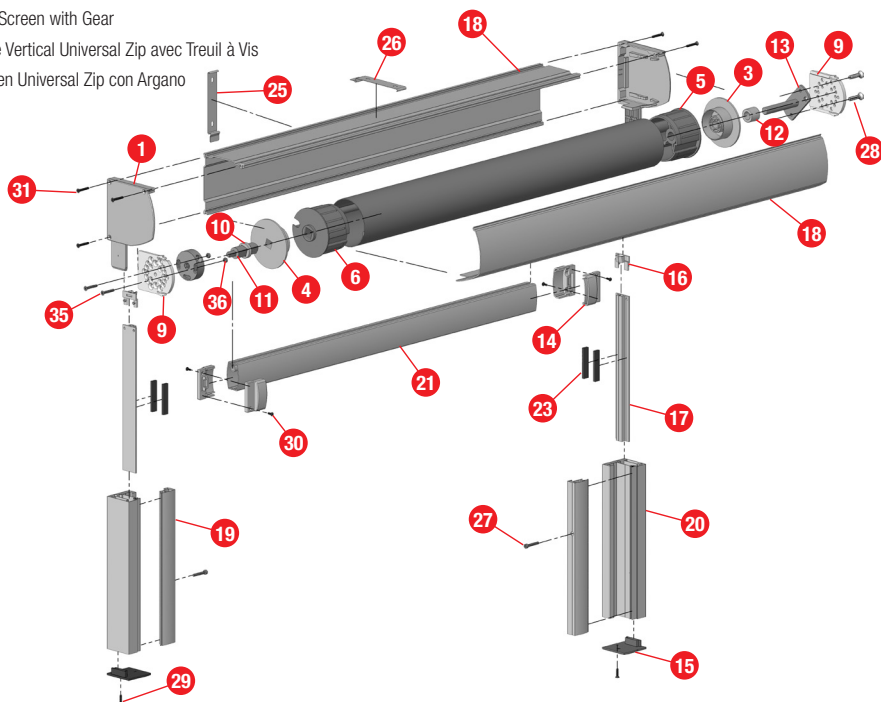

**(E)** Listado de descuentos para el montaje del Screen Universal Zip.

**(F)** Tableau de coupe à mesure pour montage du Screen Universal Zip.

**(GB)** Cutting list for Universal Zip Screen assembly.

**(I)** Elenco degli elementi per il montaggio dello Screen Universal Zip.



PERFIL CAJÓN / BOX PROFILE PROFIL CAISSON / PROFILO CASSONETTO FISSO	X - 30 mm
PERFIL REGISTRO / FRONTAL PROFILE PROFIL BÔÎTIER / PROFILO CASSONETTO ISPEZIONABILE	X - 5 (+0/-0,5) mm
PERFIL GUÍA ANTERIOR / FRONTAL GUIDE PROFILE PROFIL COULISSE ANTÉRIEUR / PROFILO GUIDA ALLUMINIO FISSA	Y - 103 mm
PERFIL GUÍA POSTERIOR / REAR GUIDE PROFILE PROFIL COULISSE POSTÉRIEUR / PROFILO GUIDA ALLUMINIO ISPEZIONABILE	Y - 103 mm
PERFIL BARRA CARGA / CHARGE PROFILE PROFIL BARRE DE CHARGE / PROFILO BARRA TERMINALE IN ALLUMINIO	X - 123 (±0,5) mm
PERFIL CIERRE LONA PVC / CLOSING PROFILE, PVC FABRIC PROFIL FERMETURE TOILE PVC / PROFILO GUIDA IN PVC PER ZIP/TELO	Y - 115 (+0/-1) mm
TUBO OJIVA Ø 78-70 / Ø 78-70 OGIVE TUBE TUBE À GORGE Ø 78-70 / RULLO OGIVA Ø 78-70	X - 115 mm
LONA SCREEN C/CREMALLERA SCREEN FABRIC WITH ZIPP TOILE SCREEN À CRÉMAILLÈRE TESSUTO SCREEN CON ZIP	X - 73 mm Y + 300 mm
BARRA REFUERZO ACERO Ø 22 Ø 22 STEEL EFFORT BAR BARRA RENFORT ACIER Ø 22 BARRA CONTRAPPESO IN ACCIAIO Ø 22	Motor/Moteur/Motore: 3 Kg/m  Cardan: 1 Kg/m
NEOPRENO AUTO-ADHESIVO 10 X 4 mm 10 X 4 MM SELF-ADHESIVE NEOPRENE NÉOPRÈNE AUTOCOLLANT 10 X 4 mm AUTO-ADESIVO IN NEOPRENE 10 X 4 mm	2 pzs. cada 40 cm 2 pieces per every 40 cm 2 pièces chaque 40 cm 2 pezzi ogni 40 cm

Rango de Uso / Range of Use  
Tableau de Mesures / Campo di Applicazione

TUBO / TUBE TUBE / TUBI	ANCHURA / WIDTH LARGEUR / LARGHEZZA	ALTURA / HEIGHT HAUTEUR / ALTEZZA
Ø 70	4000	3500
Ø 78	4000	2700

**(E)** Instalación del Screen Universal Zip a pared o a techo.

**(GB)** Universal Zip Screen assembly to either wall or ceiling.

**(F)** Installation Screen Universel Zip à mur ou à toit.

**(I)** Installazione Screen Universal Zip a parete e/o soffitto.

**(E)** Sujeción del Perfil Cajón Cofre 100 Pared/Techo: Fijar el cofre con un mínimo de tres piezas con un peso máximo por pieza de 7,5 Kg (25-26).

**(GB)** Support of the 100 Box Profile to Wall/Ceiling: Place the box with a minimum of three pieces. The maximum weight per support would be of 7,5 Kg (25-26).

**(F)** Fixation du Profil Caisson 100 mur/toit: Fixer le coffre avec un minimum de trois pièces avec un poids maximum par pièce de 7,5 Kg (25-26).

**(I)** Sostegno Profilo Cassonetto Alto 100 a parete e/o soffitto: Fissare il cassonetto con almeno 3 supporti ricordando che il peso massimo applicabile per supporto è di 7,5 Kg (25-26).

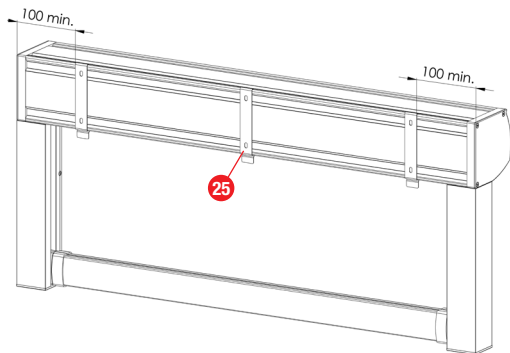

- (E)** Mecanizado de componentes para el montaje del Screen Universal Zip.

Mecanizado Lona:

- (GB)** Mechanization of Parts for the Universal Zip Screen assembly.

Mechanization of the Fabric:

- (F)** Mécanisé de composants pour le montage du Screen Universal Zip.

Mécanisé toile:

- (I)** Lavorazione dei componenti per il montaggio dello Screen Universal Zip.

Lavorazione del tessuto:

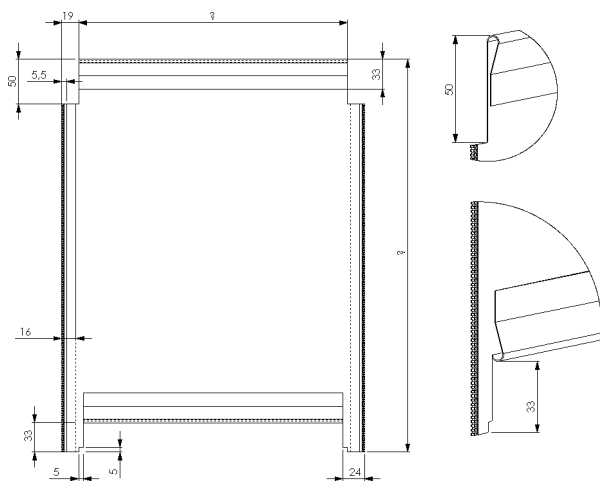

- (E)** Mecanizado perfil registro: realizar corte en ambos extremos del perfil.

- (GB)** Mechanization of the frontal profile: cut in both sides of the profile.

- (F)** Mécanisé profil boîtier: couper les deux extrémités du profil.

- (I)** Lavorazione del profilo cassonetto fisso/ispezionabile. Intestare e tagliare contemporaneamente i profili cassonetto fisso e ispezionabile.

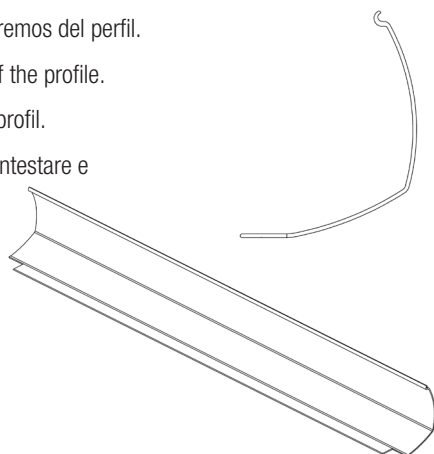
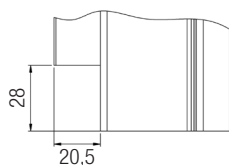

- (E)** Mecanizado perfil guía anterior: fijación de la guía anterior con la guía posterior.

- (GB)** Mechanization of the frontal guide profile: fix the rear guide with the frontal one.

- (F)** Mécanisé profil coulisse antérieur: fixation de la coulisse antérieure à la coulisse postérieure.

- (I)** Lavorazione della guida in alluminio: fissare la guida in alluminio fissa, poi chiudere con guida parte ispezionabile.

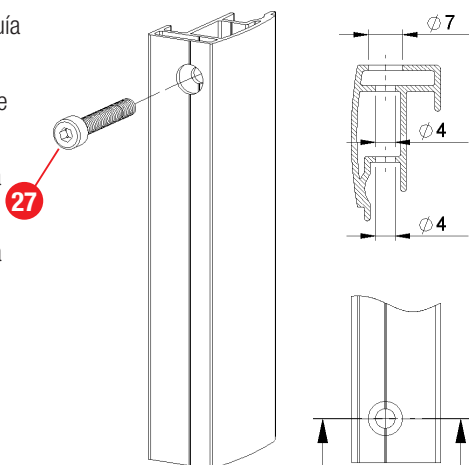

- (E)** Mecanizado perfil cierre lona: fijación del Embudo en el perfil cierre lona. Fijar dos neopreno auto-adhesivo cada 40 cm.
- (F)** Mécanisé profil fermeture toile: fixation de l'embout dans le profil fermeture toile. Fixer deux néoprènes autocollants à chaque distance de 40 cm.

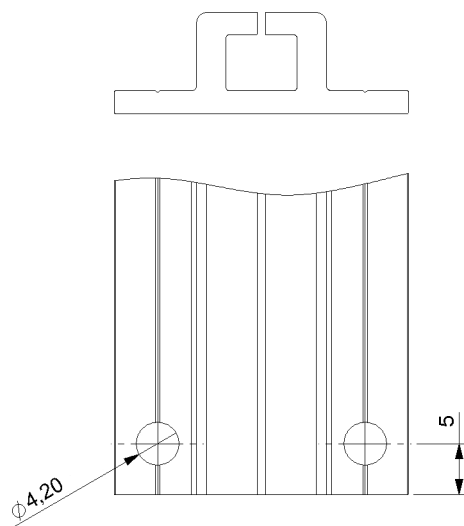

- (GB)** Mechanization of the closing profile for fabric: fix the entry guide into the closing profile for fabric. Place two self-adhesive neoprenes every 40 cm.
- (I)** Lavorazione del profilo guida zip/telo: Fissare l'invito guida zip/telo e applicare ogni 40 cm un auto-adeseivo in neoprene.

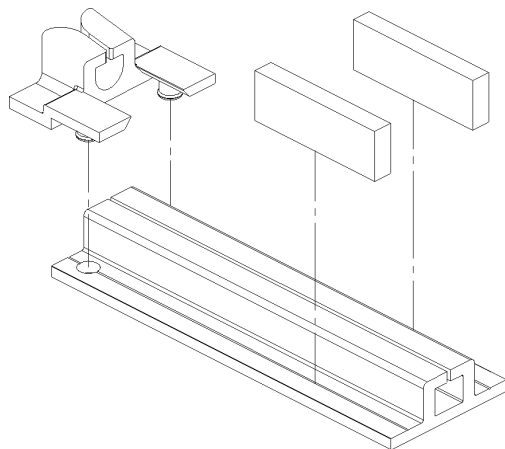

- (E)** Detalles de montaje del Screen Universal Zip: Montaje lona: fijar la parte superior de la lona mediante tornillos sobre la ojiva del tubo.
- (GB)** Universal Zip Screen assembly details: Fabric assembly: fix the upper part of the fabric with screws into the tube ogive.
- (F)** Détails de montage du Screen Universal Zip: Montage toile: fixer le côté supérieur de la toile sur la rainure de l'axe à l'aide des vis.
- (I)** Dettagli di montaggio dello Screen Universal Zip: Montaggio telo: Infilare il tessuto (appositamente lavorato con asolatura), nell'ogiva del rullo.

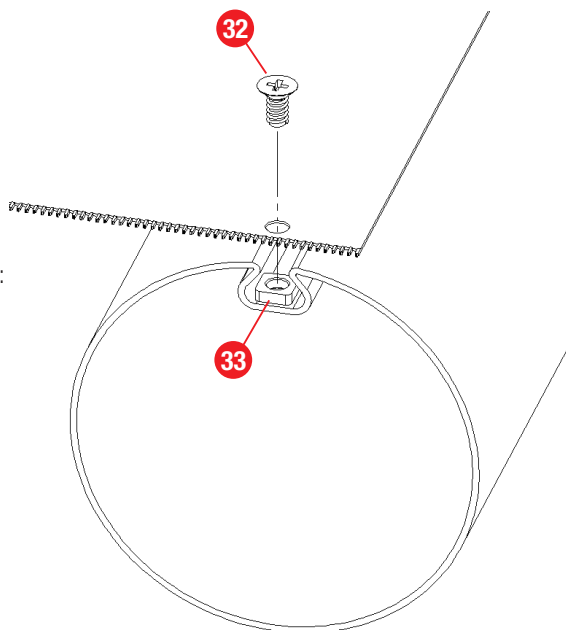

- (E)** Montaje perfil registro: atornillar el perfil registro al testero.
- (GB)** Frontal profile assembly: screw the frontal profile to the end cap.
- (F)** Montage profil boîtier: visser le profil boîtier à la console.
- (I)** Montaggio profili cassonetto: Avvitare il profilo cassonetto fisso al fianco e successivamente agganciare il profilo cassonetto ispezionabile (non deve essere avvitato, in quanto verrà sorretto dalla guida in alluminio parte ispezionabile).

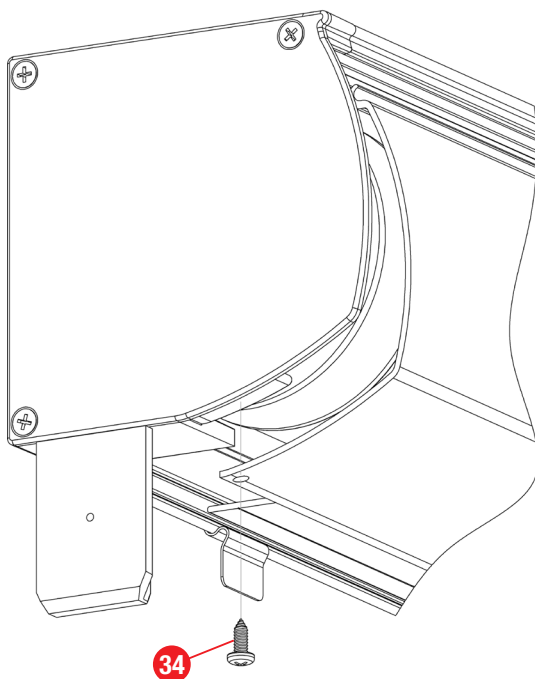

- (E)** Montaje felpudos: introducir felpudo en el perfil barra carga y el perfil cajón.
- (F)** Montage joint brosse: introduire le joint brosse dans le profil barre de charge et le profil caisson.

- (GB)** Mats assembly: place the mat into the charge profile and the box profile.
- (I)** Montaggio spazzolini: introdurre lo spazzolino nel profilo cassonetto e nella barra terminale.

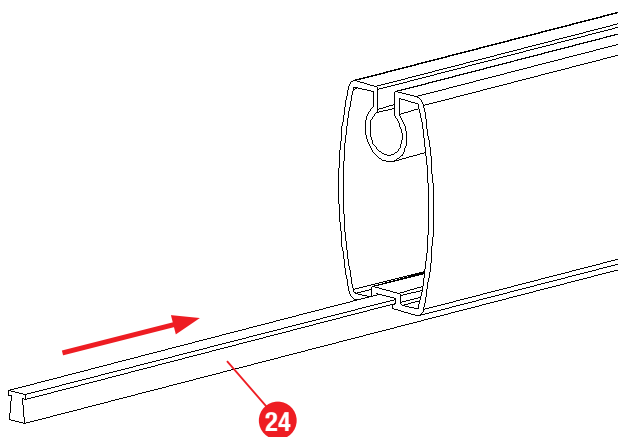

**(E)** Montaje lona: fijar la parte inferior de la lona mediante los tornillos del tope barra carga según imagen adjunta.

**(F)** Montage toile: fixer la partie inférieure de la toile à l'aide des vis de l'embout terminal de la barre de charge comme indiqué sur l'image.

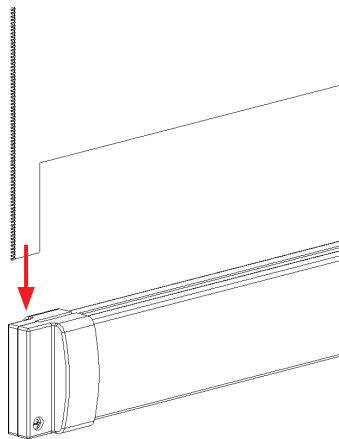

**(GB)** Fabric assembly: fix the lower part of the fabric with the screws of the charge profile stopper as shown.

**(I)** Montaggio tessuto: Infilare il tessuto (appositamente lavorato con asolatura) nell'ogiva della barra terminale.

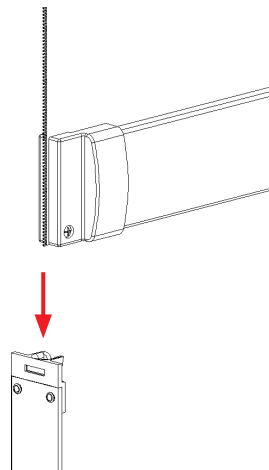

**(E)** Montaje barra carga: introducir la barra de acero en el perfil barra de carga:  
Motor: 3 Kg/m - Cardan: 1 Kg/m

**(F)** Montage barre de charge: introduire la barre de charge dans le profil barre de charge:  
Moteur: 3 Kg/m - Cardan: 1 Kg/m

**(GB)** Charge profile assembly: place the steel bar into the charge profile:  
Motor: 3 Kg/m - Cardan: 1 Kg/m

**(I)** Montaggio profilo terminale: introdurre la barra d'acciaio nel profilo barra terminale:  
Motore: 3 Kg/m - Cardan: 1 Kg/m

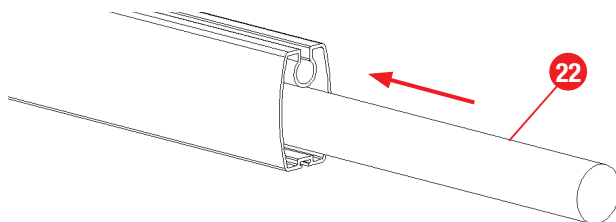



Zip with Motor:

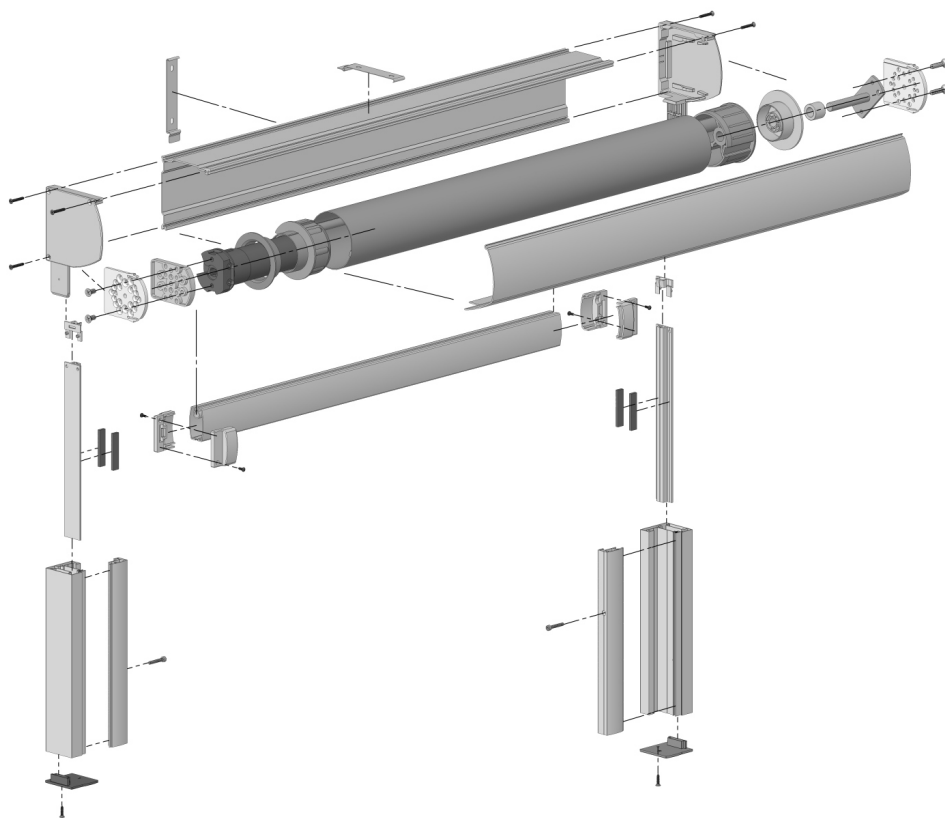

## Zip with Gear:

